

START HERE!

READ ME FIRST

Don't be a hero and muscle through this installation without reading these fitting instructions first! Improper installation of this gear may void certain aspects of your warranty.

Before you begin, take a moment and open all your Front Runner rack kit boxes and gather the assembly instructions for the various components.

A complete kit will contain:

1. A Front Runner Mounting System specific to your vehicle
2. A Front Runner Rack Tray or Load Bar Slats

This document will guide you through the assembly of the mounting system and assist you in fitting the roof rack tray or load bars to your specific vehicle.

Please refer to the next page for a list of all the components, quantities and tools required.

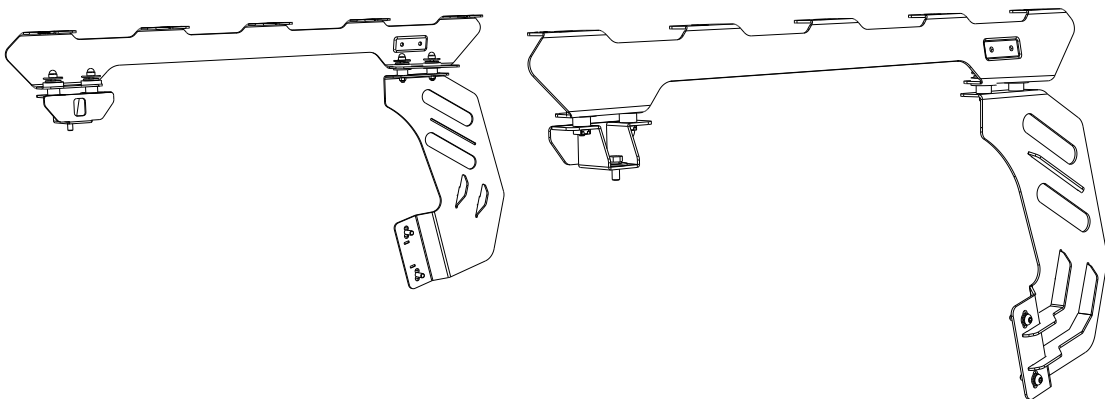

IMPORTANT WARNING! ⚠

IT IS CRITICAL THAT ALL FRONT RUNNER PRODUCTS BE PROPERLY AND SECURELY ASSEMBLED AND ATTACHED TO YOUR VEHICLE. IMPROPER ATTACHMENT COULD RESULT IN AN AUTOMOBILE ACCIDENT, AND COULD CAUSE SERIOUS BODILY INJURY OR DEATH. YOU ARE RESPONSIBLE FOR ASSEMBLING AND SECURING ALL FRONT RUNNER PRODUCTS TO YOUR VEHICLE, CHECKING THE ATTACHMENTS PRIOR TO USE, AND PERIODICALLY INSPECTING THE PRODUCTS FOR ADJUSTMENT, WEAR AND DAMAGE. THEREFORE, YOU MUST READ AND UNDERSTAND ALL OF THE INSTRUCTIONS AND PRECAUTIONS SUPPLIED WITH YOUR FRONT RUNNER PRODUCT PRIOR TO INSTALLATION OR USE. IF YOU DO NOT UNDERSTAND ALL OF THE INSTRUCTIONS AND CAUTIONS, OR IF YOU HAVE NO MECHANICAL EXPERIENCE AND ARE NOT THOROUGHLY FAMILIAR WITH THE INSTALLATION PROCEDURES, YOU SHOULD HAVE THE PRODUCT INSTALLED BY A PROFESSIONAL INSTALLER OR OTHER QUALIFIED PERSONNEL.

NOTE: Front Runner will not be responsible for any damage caused by the failure to install the product according to these instructions.

Please call us if you have any questions about the installation of this product.

1

GET ORGANIZED

FAJL005

IN THE BOX

1	2 X	Foot Rail - 1LH + 1RH
2	10 X	M8 X 20 Hex Bolt
3	10 X	M8 x 16 x 1.6SS Flat Washer
4	10 X	M8 Nyloc Nut
5	10 X	M8 Nut Cap

TOOLS NEEDED

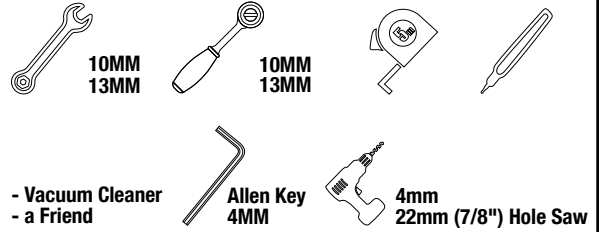
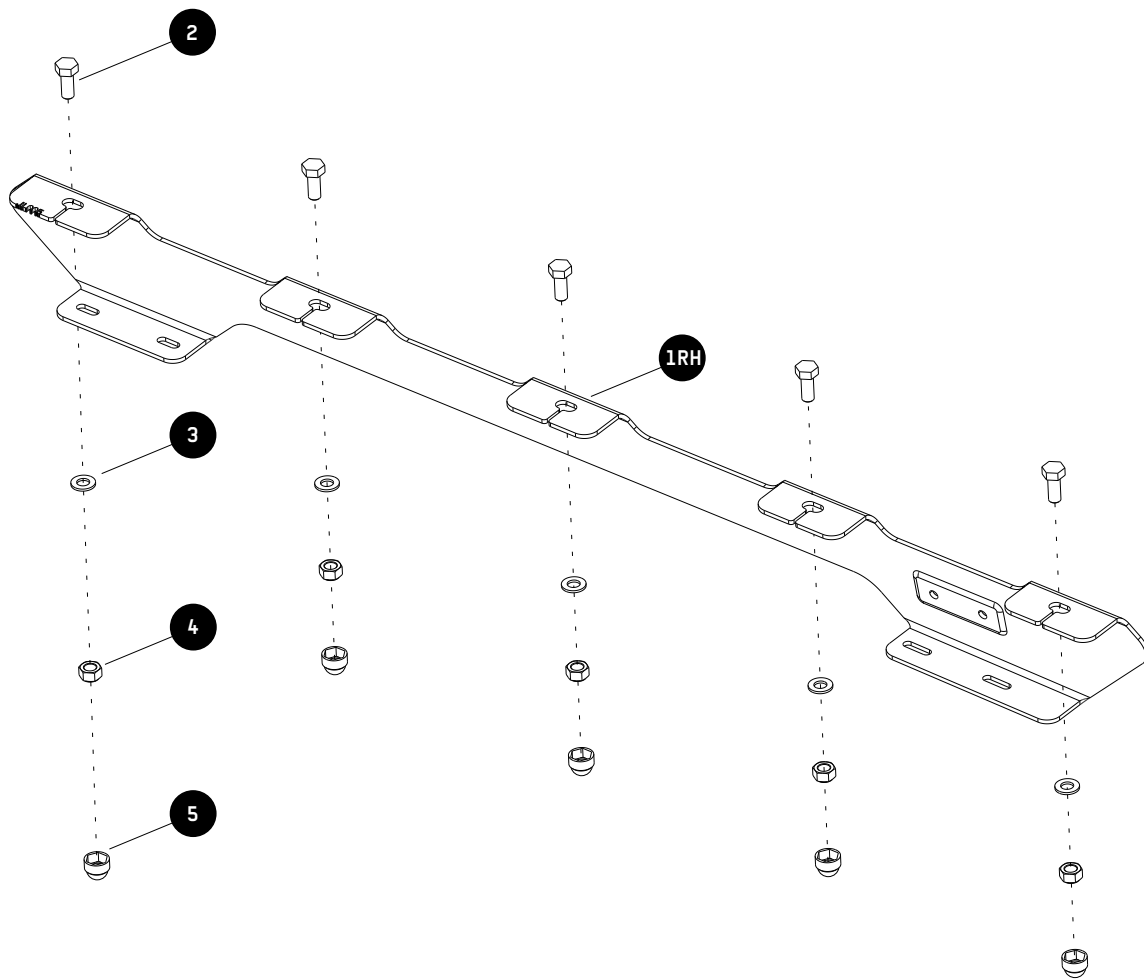

FIGURE 1.2



1

GET ORGANIZED

FAJL006

IN THE BOX

6	2 X	Rear Inner Bracket - 1LH + 1RH
7	2 X	Middle Support Bracket
8	8 X	M6 Nut Cap
9	8 X	M6 x 40 Hex Bolt
10	8 X	M6 x 30 x 2 Washer
12	8 X	Aluminum Spacer
13	8 X	Foam Seal Washer
14	4 X	M8 x 25 Button Head Bolt
15	6 X	M8 SS Spring Washer
16	4 X	M8 x 16 x 1.6SS Flat Washer

IN THE BOX

17	4 X	M6 Nyloc Nut
18	4 X	M6 x 12 x 1SS Flat Washer
19	2 X	M8 x 25 x 2 Flat Washer
20	2 X	M8 x 20 Hex Bolt
21	4 X	M6 Cage Nut
22	4 X	M6 SS Spring Washer
23	1 X	Seal Kit

FIGURE 1.1

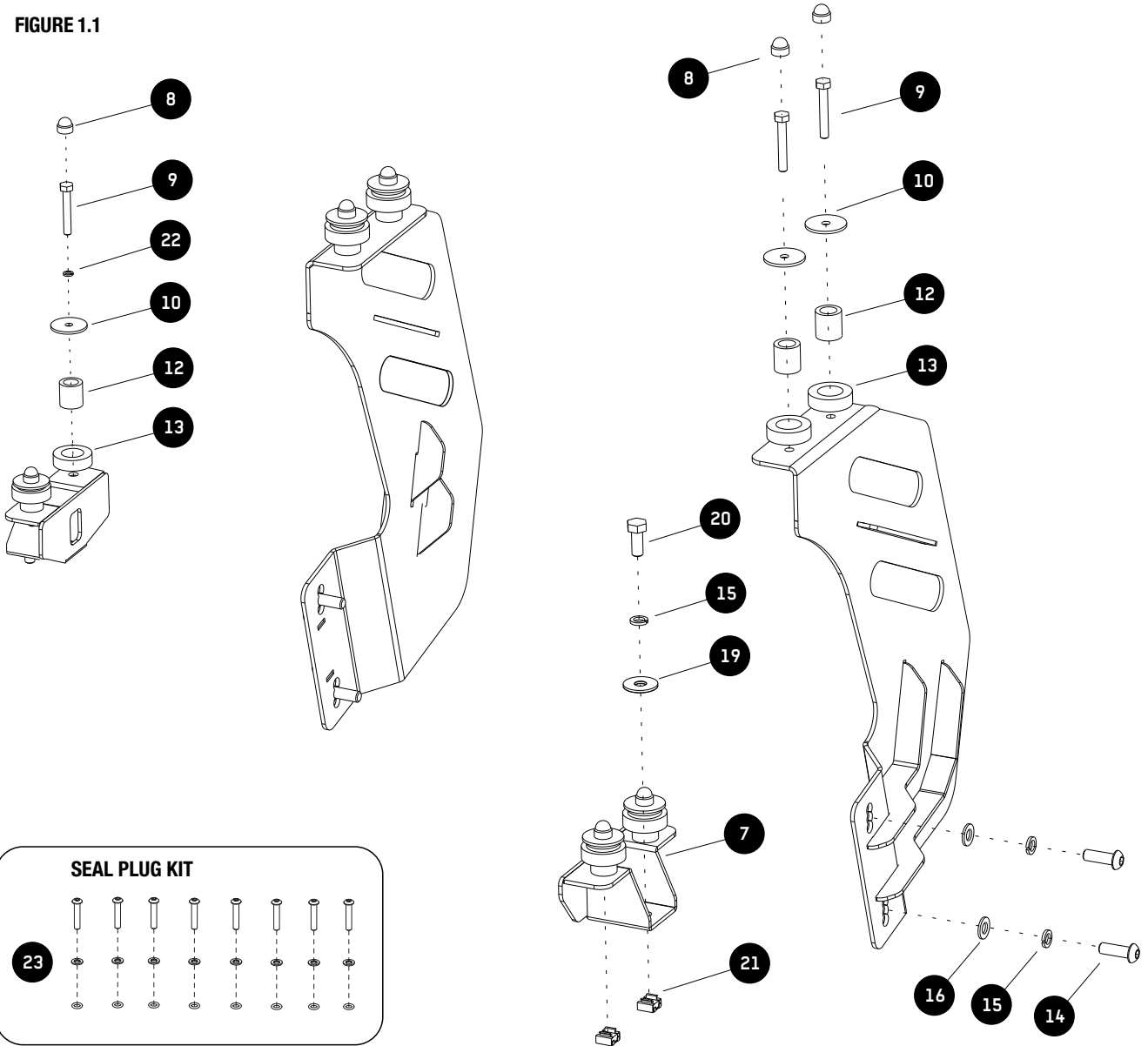

2

FIT AND SECURE INNER BRACKETS AND FOOT RAIL

2.1

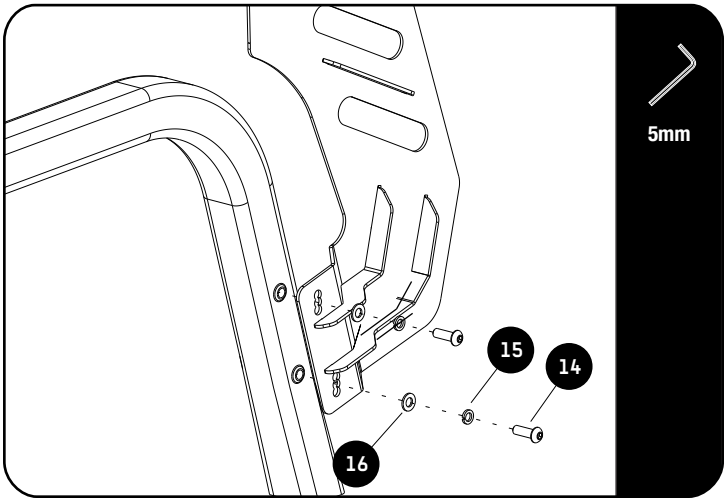

Fit the Inner Support Brackets (Items 6LH & 6RH) to the factory inserts in the roll bar, using M8 x 25 Button Head Bolts, M8 SS Spring Washer and M8 x 16 x 1.6SS Flat Washer (Items 14, 15 & 16).

2.2

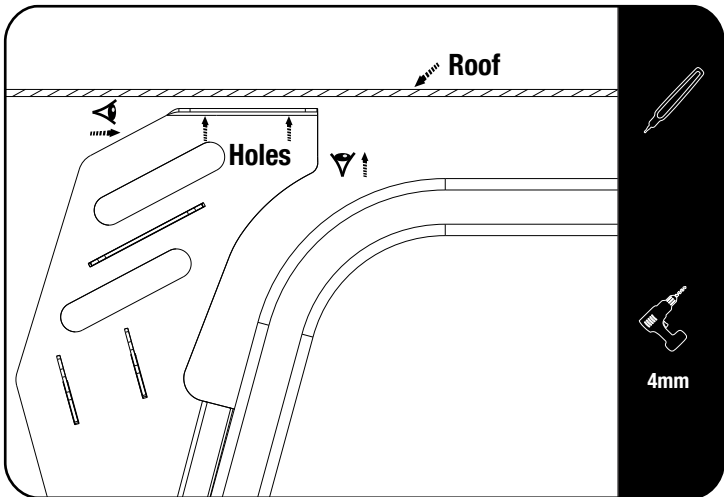

Looking from the side ensure that the top of the Inner Support Bracket is parallel with the inside of the roof and looking from the back must sit parallel with the rib in the roof.

Using the two top holes on the Inner Support Bracket as a guide, mark the hole positions on the roof. Do the same with the opposite side Support Bracket.

Remove the brackets and drill a 4mm pilot holes on all four marks you have made.

2.3



Remove the two T-top roofs.

Disconnect the power socket and water pipe in the back left corner of the vehicle.

Using a T40 Torx Wrench, remove the six torx bolts holding the rear roof to the vehicle's body.

Remove the two remaining torx bolts either side above the front headrests holding the rear roof to the vehicle's body.

With the help of a friend, lift the roof off the vehicle.

2

FIT AND SECURE INNER BRACKETS AND FOOT RAIL

2.4

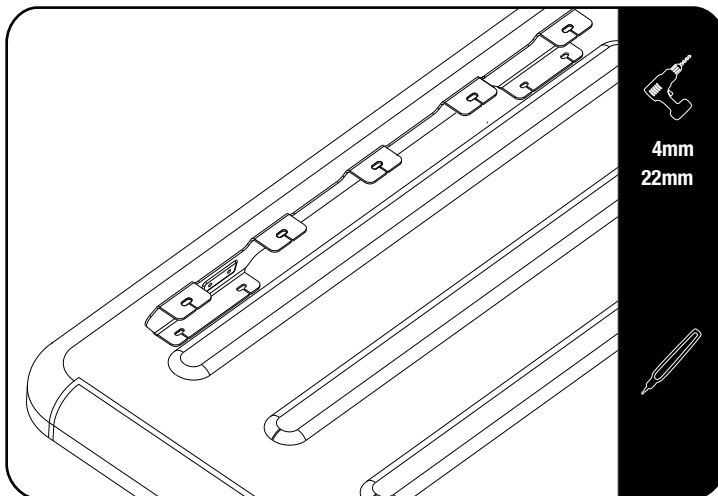

Working from the outside of the roof align the rear two holes in the foot rails with the holes drilled in 2.2.

Ensure that the foot rail runs parallel to the rib on the roof before marking the two front holes in the foot rail onto the roof.

Do this on both left and right side.

Remove the rails and drill 4mm pilot holes on the marks you just made.

Change the 4mm drill bit to a 22mm hole saw. From the outside of the vehicle, drill all the 4mm holes (8 in total) out to 22mm. Let the drill do the work. You do not want to scratch or damage your vehicle's roof. Have your friend hold a vacuum cleaner below where you are drilling to catch all the dust.

After drilling, clean the area around all the 22mm holes in the roof with a rag and methylated spirits/denatured alcohol.

2.5

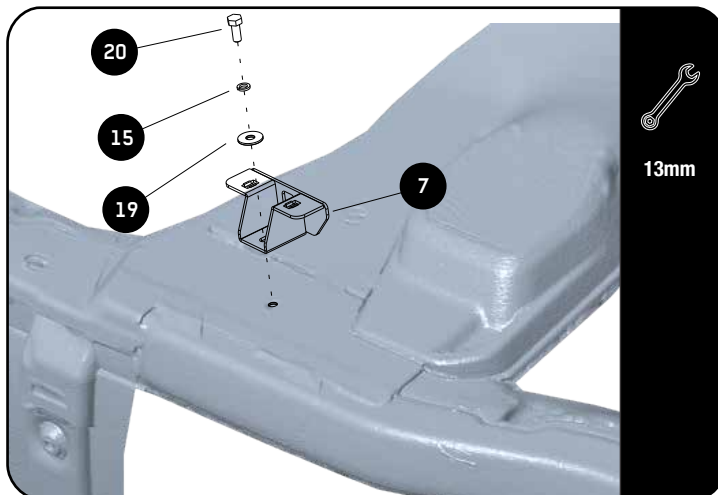

Secure the Middle Support Brackets (Items 7) onto the factory inserts in the roll bar where shown, using M8 x 20 Hex Bolts, M8 SS Spring Washer and M8 x 25 x 2 Flat Washer (Items 15, 19 & 20).



The angled edge of the bracket should face to the outside of the vehicle.

2.6

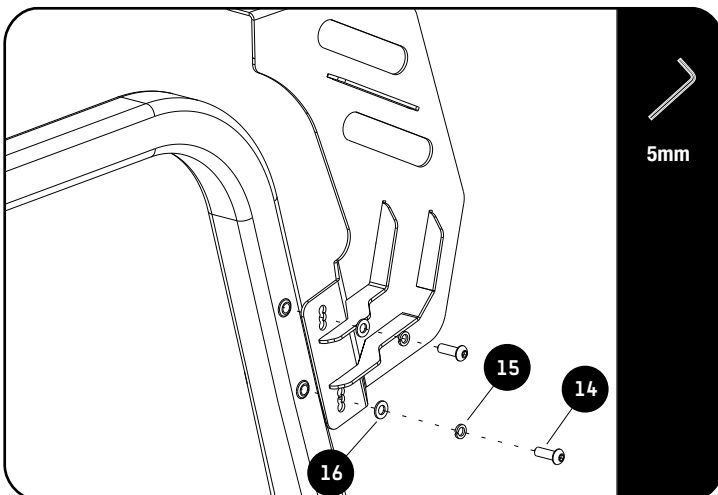

Refit the roof, and fully tighten all six torx bolts removed.

Reconnect the power socket and water pipe in the back left corner of the vehicle.

Refit the Inner Support Brackets to the roll bar.

2

FIT AND SECURE INNER BRACKETS AND FOOT RAIL

2.7

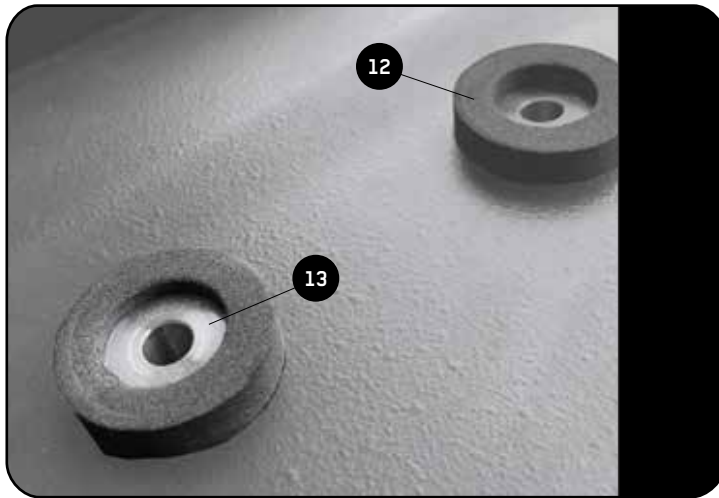

Insert the Aluminum Spacers (Item 12) into the Foam Washer (Item 13). Remove the paper backing from the Foam Washer to expose the adhesive.

Insert the Washer/Spacer combination, adhesive side down, into the 22mm holes so that the Spacer comes to rest on the Inner and Middle Support Brackets.

Firmly press the Foam Washer all the way around, securing it to the roof.

2.8

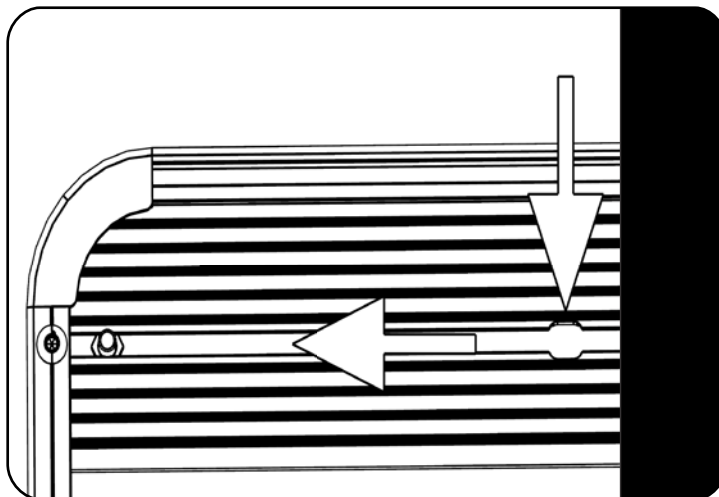

For a Full Rack fitment refer to FAJL004



If not already assembled, assemble your Tray as per the Universal Tray Assembly Instructions (Document RRTUNI)



NOTE: Before fitting the Wind Deflector, insert two M8 x 16 Hex Bolts (Item 11 from FAJL005) or if you are fitting a full rack (Item 1 from FAJL004) into the first slat (Combined Slat), using the Machined slots. Slide a bolt to each of the outer corners.

2.9

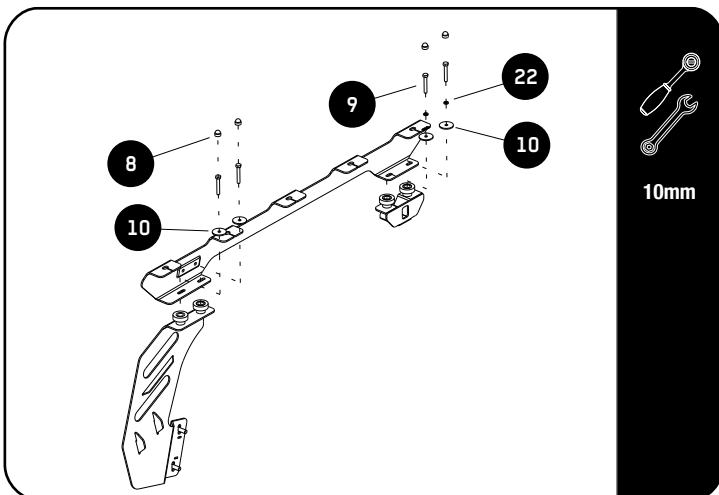

Place the Foot Rail (Item 1) onto the spacer and secure using M6 x 40 Hex Bolts, M6 x 30 x 2 Flat Washers, M6 SS Spring Washers, M6 x 12 x 1SS Flat Washer and M6 Nyloc Nuts (Items 8, 9, 10 & 22) as shown. Do this on both sides of the vehicle.



Take note of the M6 SS Spring Washers (Item 22) on the Middle Support Bracket.

Finish off by placing M6 Nut Caps (Item 8) over all the bolt heads.

3

FIT AND SECURE ROOF RACK

3.1

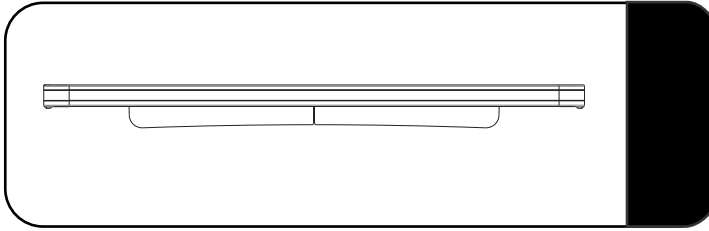

Make sure that the wind deflector is installed before you proceed to the next step.

Refer to Rack Fitment Guide (RRSTUNI).

3.2

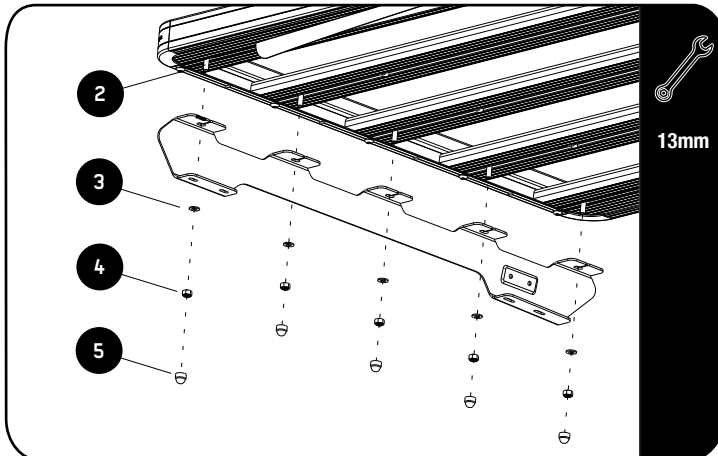

Fit your Roof Rack to the Foot Rails using M8 x 20 Hex Bolts, M8 x 16 x 1.6SS Flat Washers and M8 Nyloc Nuts (Items 2, 3 & 4).

3.3

Center the rack and tighten fully. Use M8 Nut Caps (Item 5) to finish off the nuts.



4

REMOVING YOUR RACK

4.1

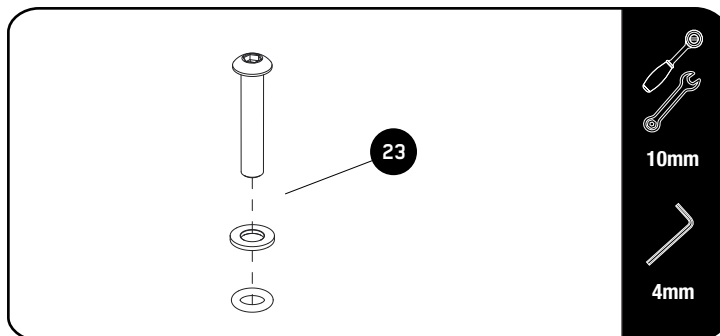

Should you wish to remove your rack, you will need to seal the holes you drilled in the roof (Step 2.5) using the supplied Seal Plug Kit.

Remove the Tray and the Foot Rail by reversing the installation procedure.

Leave the Foam Washer and the Aluminum Spacers in place. Screw in the Sealing Plugs, reusing the M6 Nyloc Nuts and Washers that held the Foot Rail in position.

5

COMPLETION

4.1

Congratulations! You did it. Take a step back and admire your work!



6

INSTALL OTHER VEHICLE AND RACK ACCESSORIES

Now's the time to visit your favorite Front Runner Dealer in person or online.

IMPORTANT!

FRONT RUNNER RACK KITS OFTEN HAVE A HIGHER LOAD RATING THAN THE VEHICLES THEY ARE MOUNTED TO. PLEASE REFER TO YOUR SPECIFIC VEHICLE MANUFACTURER FOR A RECOMMENDED ROOF RATING. FRONT RUNNER CANNOT BE RESPONSIBLE FOR IMPROPER LOADING BEYOND THE VEHICLE MANUFACTURER'S STATED LOAD CAPACITY.

Be sure to tag us. We love to see our gear in action! #FrontRunnerOutfitters #BornToRoam

Share your adventures on: 